



# *Oak Creek Community Development District*

**May 11, 2026**

## **Agenda Package**

### **TEAMS MEETING INFORMATION**

**MEETING ID: 231 071 929 622    PASSCODE: eraLpq**  
[Join the meeting now](#)

2005 Pan Am Circle, Suite 300  
Tampa, FL 33607

## **CLEAR PARTNERSHIPS**



**COLLABORATION**



**LEADERSHIP**



**EXCELLENCE**



**ACCOUNTABILITY**



**RESPECT**

# Oak Creek Community Development District

## Board of Supervisors

Sam Watson, Chairman  
Michael Rudman, Vice Chairperson  
Ryan Gilbertsen, Assistant Secretary  
Lisa Vaile, Assistant Secretary  
David Gerald, Assistant Secretary

## District Staff

Christina Newsome, District Manager  
Cari Allen Webster, District Counsel  
Robert Dvorak, District Engineer  
Carlos Santana, On-Site Manager  
Christian Haller, District Accountant  
Melinda Gallo, District Admin

### Regular Meeting Agenda

Monday May 11, 2026, at 6:00 p.m.

The Regular Meeting of the **Oak Creek Community Development District** will be held on Monday May 11, 2026, at 6:00 p.m. at the Watergrass Clubhouse, at 32711 Windelstraw Dr., Wesley Chapel, FL 33545. Please let us know at least 24 hours in advance if you are planning to call into the meeting. Following is the Agenda for the Meeting:

[Join the meeting now](#)

**Meeting ID:** 231 071 929 622      **Passcode:** eraLpq

**Dial-in by Phone:** +16468381601      **Pin:** 650458735#

## THE REGULAR MEETING OF BOARD OF SUPERVISORS

1. CALL TO ORDER/ROLL CALL
2. PLEDGE OF ALLEGIANCE
3. APPROVAL OF AGENDA
4. PUBLIC COMMENTS

*(Each individual has the opportunity to comment and is limited to three (3) minutes for such comment)*

### 5. STAFF REPORTS

#### A. District Accountant

- i. Review of Financial Snapshot .....P. 4

#### B. District Counsel

#### C. District Engineer

#### D. District Manager

- i. Announcing the Number of Qualified Registered Voters in the District (1,038).....P. 5

#### E. Field Manager Report .....P. 6

- i. Consideration of Triangle Pool Services for Pool Salt System Repairs Proposal .....P. 9
- ii. Consideration of Mike’s Signs Amenity Center Hours Signage Proposal .....P. 10
- iii. Discussion of Trash Can Lid Replacement at Amenity Center Options

- Bonnet Top – \$275 (plus shipping).....P. 12
- Dome – \$325 (plus shipping) .....P. 14
- Dome with Ash Urn – \$365 (plus shipping) .....P. 16

F. Aquatics Report

G. Landscape Report

**6. BUSINESS ADMINISTRATION**

A. Consideration of Minutes from the Meeting held April 13, 2026.....P. 18

**7. BOARD OF SUPERVISORS REQUESTS AND COMMENTS**

**8. ADJOURNMENT**

# OAK CREEK COMMUNITY DEVELOPMENT DISTRICT

---

## Financial Snapshot May 11, 2026

- **Current Cash Balances:**
  - Valley Operating: \$638,638.
  - BankUnited MM: \$378,627.
- **Assessment collections:**
  - We received a tax distribution of \$13,556 on 3/12/26.
  - We are 97% collected on the tax roll.
- **Expenses:**
  - Current expenses make up 54% of the annual budget through the end of March 2026.
  - Total expenses for the first 6 months are approximately \$409,596. This puts your average monthly burn rate of approximately \$68,266 per month.
  - April financials will be distributed to the board by May 20<sup>th</sup>.

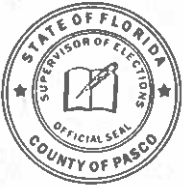

**Brian E. Corley**  
**Supervisor of Elections**  
PO Box 300  
Dade City FL 33526-0300

**1-800-851-8754**  
**www.PascoVotes.gov**

April 17, 2026

Melinda Gallo  
District Administrative Assistant II  
313 Campus St  
Celebration FL 34747

Dear Melinda Gallo:

Pursuant to your request, the following voter registration statistics are provided for their respective community development districts as of April 15, 2026.

- Oak Creek Community Development District 1,038

As always, please call me if you have any questions or need additional information.

Sincerely,

A handwritten signature in black ink, appearing to read "Tiffannie A. Alligood". The signature is fluid and cursive, with a large loop at the end.

Tiffannie A. Alligood  
Chief Administrative Officer

Oak Creek CDD – Monthly Manager Report

Prepared by: Carlos Santana

Position: Onsite Manager

Management Company: Inframark

Community: Oak Creek CDD

Reporting Period: April 13, 2026 – May 1, 2026

Detailed Activity Log

Monday, April 13

- Conducted full site walkthrough and amenity inspections
- Coordinated vendor communications with Juniper and Triangle Pool
- Attended CDD meeting
- Responded to resident emails and service requests

Tuesday, April 14

- Followed up with PPW regarding pressure washing scheduling
- Cleaned community restroom and amenity furniture
- Coordinated with Louis Electric regarding lighting updates
- Addressed resident inquiry regarding property maintenance responsibilities

Wednesday, April 15

- Emptied dog waste stations throughout the community
- Performed trash pickup around common areas
- Conducted general site walkthrough and inspections

Thursday, April 16

- Conducted key fob appointments for residents
- Followed up with vendors regarding ongoing proposals
- Performed amenity and facility checks

Friday, April 17

- Responded to Oak Creek CDD emails and resident requests
- Coordinated with vendors regarding scheduling updates
- Performed general maintenance tasks around amenity areas

Monday, April 20

- Conducted site walkthrough and vendor follow-ups

- Coordinated with Juniper regarding landscaping services
- Completed administrative tasks and documentation updates
- Reviewed ongoing service items and community maintenance needs

Tuesday, April 21

- Communicated with Martin Security Services regarding security camera proposal and meeting availability
- Followed up with vendors on outstanding proposals
- Conducted amenity inspections
- Responded to resident communications

Wednesday, April 22

- Cleaned amenity restrooms and common areas
- Emptied dog waste stations
- Conducted general site walkthrough
- Performed trash pickup around amenity areas

Thursday, April 23

- Coordinated with vendors regarding scheduling and project updates
- Completed administrative follow-ups and documentation
- Conducted facility inspections

Friday, April 24

- Cleaned pavilion seating areas
- Performed leaf blowing around amenity center
- Addressed minor maintenance items
- Ensured amenity areas were prepared for weekend use

Monday, April 27

- Conducted site walkthrough and vendor coordination
- Reviewed community maintenance needs
- Responded to resident communications
- Followed up on ongoing vendor services

Tuesday, April 28

- Followed up with Triangle Pool regarding ongoing service
- Coordinated with Juniper for landscaping needs
- Completed administrative tasks and documentation

Wednesday, April 29

- Cleaned amenity restrooms and trash receptacles
- Emptied dog waste stations
- Conducted general inspections
- Performed light maintenance tasks

Thursday, April 30

- Followed up with vendors regarding proposals and scheduling
- Performed site walkthrough
- Completed administrative coordination tasks

Friday, May 1

- Conducted site walkthrough and amenity inspections
- Responded to resident emails
- Performed general maintenance tasks
- Prepared amenity areas for weekend use

#### General Maintenance Notes

Community trash pickup, restroom cleaning, and leaf blowing were performed daily as needed throughout the reporting period.

**ESTIMATE**

**Triangle Pool Services**  
 12801 Belcher Rd S  
 Largo, FL 33773

billing@triangle-pool.com  
 +1 (727) 531-0473  
 www.triangle-pool.com



**Bill to**  
 OAK CREEK CDD  
 ATTN: MARK VEGA  
 2654 CYPRESS RIDGE BLVD., SUITE 101  
 WESLEY CHAPEL, FL 33544

**Ship to**  
 OAK CREEK CDD  
 34300 SPRING OAK TRAIL  
 WESLEY CHAPEL, FL 33545

**Estimate details**

Estimate no.: 8876393561  
 Estimate date: 04/15/2026

#	Date	Product or service	Description	Qty	Rate	Amount
1.			POOL SALT SYSTEM			
2.	04/15/2026	<b>CP ESTK12.5SM</b>	12.5SM REPLACEMENT CELL STACK FOR CHLOR KING	1	\$9,999.95	\$9,999.95
3.		<b>CP CH6</b>	CELL HOUSING 6" FOR CHLOR KING	1	\$1,599.95	\$1,599.95
4.		<b>SERVICE-LABOR</b>	SERVICE CALL / LABOR	2	\$175.00	\$350.00
5.		<b>IF YOU HAVE ANY QUESTIONS, PLEASE EMAIL REPAIR@TRIANGLE-POOL.COM</b>		1	\$0.00	\$0.00

**Total** **\$11,949.90**

**Note to customer**

REVISED: ESTIMATE TO REPLACE DEPLETED CELL AND CRACKED HOUSING FOR COMMERCIAL SALT SYSTEM. CELL IS CURRENTLY BYPASSED DUE TO LEAK. 3 YEAR LIMITED AND PRORATED WARRANTY

**Accepted date**

**Accepted by**

**ESTIMATE**

Fields Consulting Group, LLC  
 (dba. Mike's Signs)  
 11749 Crestridge Loop  
 New Port Richey, FL 34655-0017

signsandgraphicsbymike@gmail.com  
 m  
 +1 (727) 480-6514



**Meritus**

**Bill to**  
 Inframark  
 Oakcreek CDD  
 Attn: Carlos Santana  
 2005 Pan Am Circle #300  
 Tampa, FL 33607

**Estimate details**

Sales Rep: Mike Fields

Estimate no.: 1873  
 Estimate date: 04/24/2026

#	Product or service	Description	Qty	Rate	Amount
1.	<b>Install (Signage)</b>	Amenity Center Entrance Gates "Amenity Center Hours" (18x12) custom metal sign. Install on gate door next to the existing "No Dogs Allowed" signs.	2	\$100.00	\$200.00
				<b>Total</b>	<b>\$200.00</b>

**Accepted date**

**Accepted by**

**AMENITY CENTER HOURS  
6:00AM - 10:00PM**

**NO USE PERMITTED OUTSIDE  
OF POSTED HOURS**

**VIOLATORS WILL BE SUBJECT TO  
SUSPENSION OF PRIVILEGES  
AND/OR TRESPASS ENFORCEMENT.**

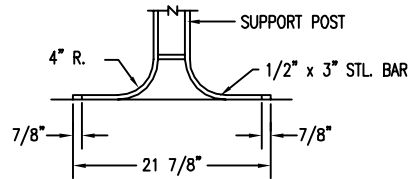
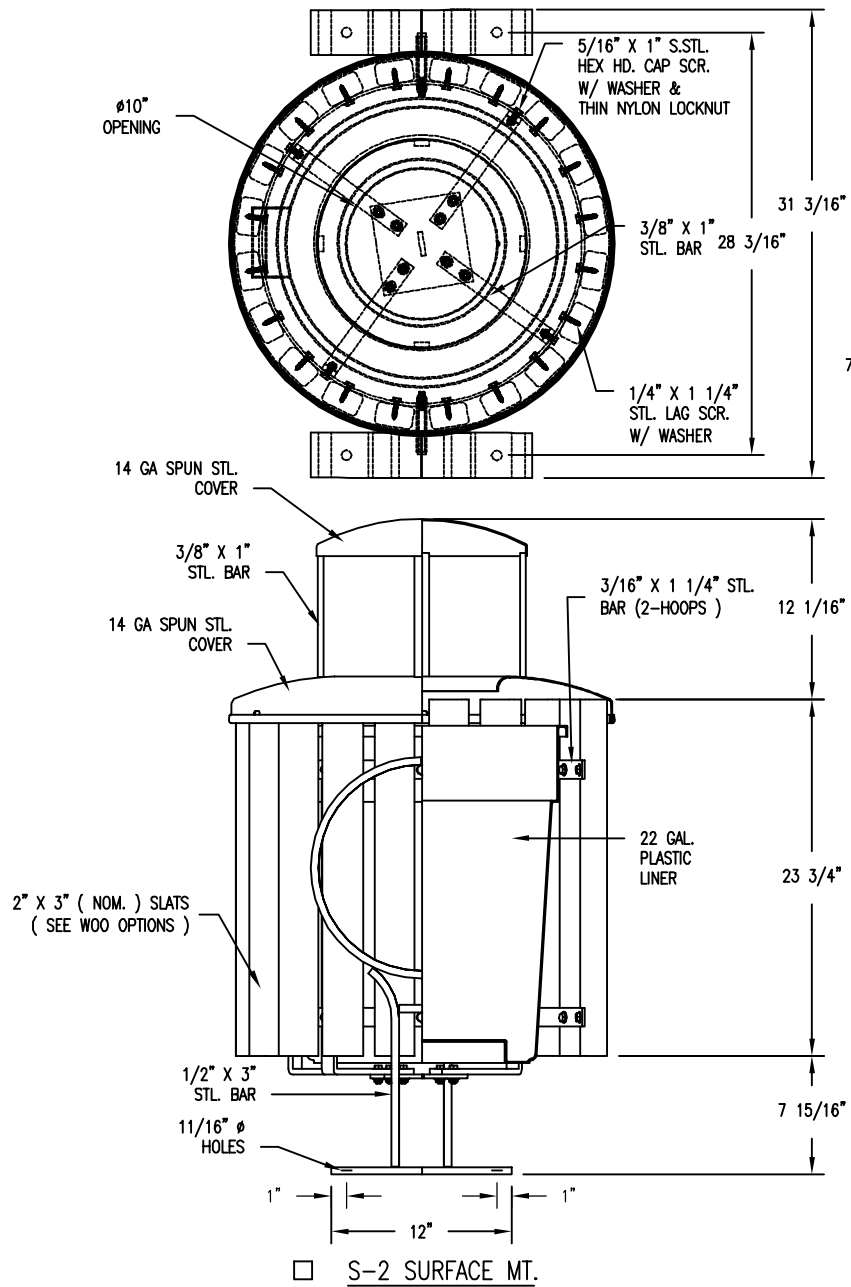

S-3 GULL WING

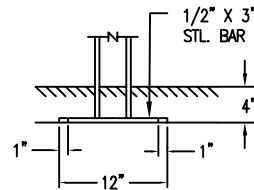

S-4 SUB FLOOR

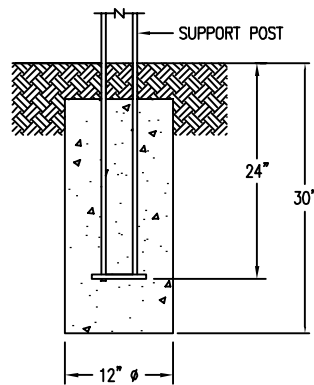

S-1 EMBEDMENT

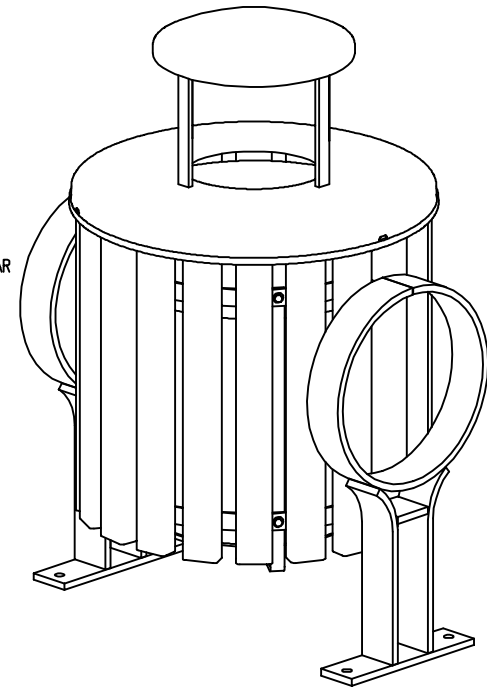

SLAT OPTIONS

- "CEDAR" RECYCLED PLASTIC
- "GREY" RECYCLED PLASTIC
- "REDWOOD" RECYCLED PLASTIC
- "WALNUT" RECYCLED PLASTIC
- OTHER \_\_\_\_\_

NOTES

- 1.) ALL STL. MEMBERS COATED W/ ZINC RICH EPOXY THEN FINISHED W/ POLYESTER POWDER COATING.
- 2.) 1/2" X 3 3/4" EXPANSION ANCHOR BOLTS PROVIDED FOR OPTIONS S-2, S-3, & S-4.



RECEPTACLE

DATE DRAWN : 02/18/02  
 DRAWN BY : AWH  
 DATE REV. : 10/08/06  
 REV. BY : AWH

REV.  
 B

DRAWING  
 NUMBER

85-22PL  
 W/ CVR-30-BT

SHEET  
 1 OF 2

**NOTES:**

- 1.) DURING ASSEMBLY PROCEDURE;  
DO NOT COMPLETELY TIGHTEN HARDWARE.
- 2.) THE ACTUAL PARTS WILL NOT BE NUMBERED.  
NUMBERS ONLY APPLY TO DRAWING.
- 3.) UPON COMPLETION OF ASSEMBLY SQUARE  
ALL COMPONENTS THEN TIGHTEN ALL HARDWARE.
- 4.) MOUNT AND ANCHOR AS SPECIFIED.

**TOOLS REQ'D**

- 3/4" WRENCH
- 9/16" WRENCH
- 1/2" WRENCH
- 7/16" WRENCH
- PLIERS ( FOR ATTACHING COVER )
- 1/2" MASONRY DRILL BIT
- DRILL

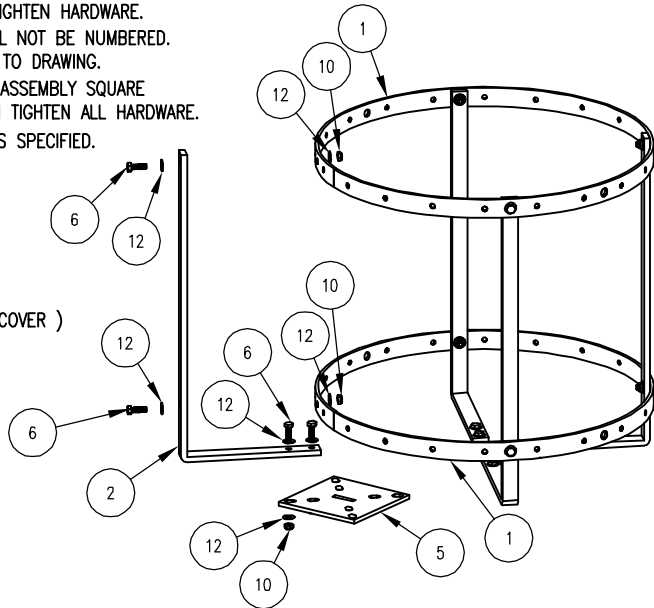

**1** ATTACH HOOPS, CENTER PLATE & "L" SUPPORT STRAPS TOGETHER.

**2** ATTACH SLATS TO STEP 1.

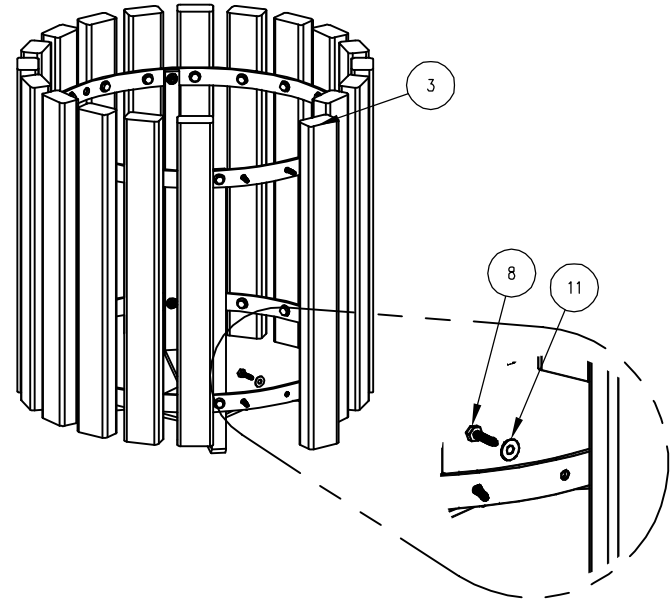

**3** ATTACH SUPPORTS TO STEP 2.

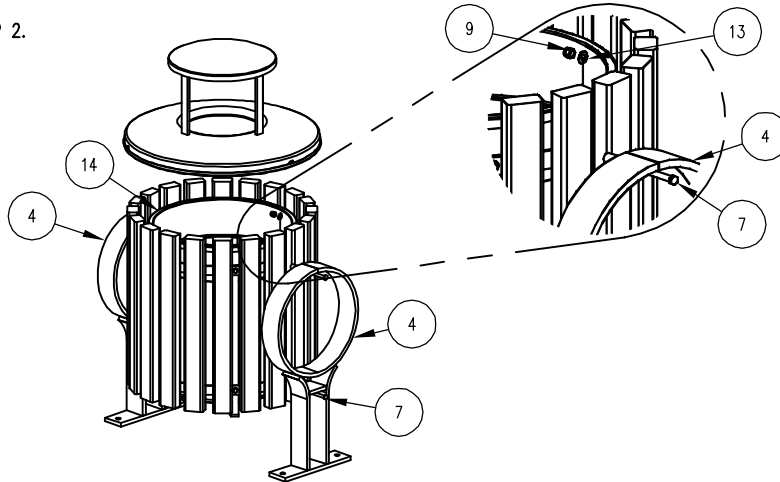

**PARTS LIST FOR S-2**

ITEM	QTY	PART NO	DESCRIPTION
1	2	0-41-20-02	HOOP FOR 20 GAL ( 21 11/16" DIA )
2	4	0-41-20-05	"L" SUPPORT STRAP FOR 20 GAL
3	20	0-41-20PL-01	2" X 3" X 23 3/4" SLAT, PLASTIC
4	2	0-85-00-01/S-2	SUPPORT FOR SURFACE MOUNT
5	1	0-85-00-02	CENTER PLATE ( 85 )
6	16	1-12-061	5/16" X 1" SS HEX HD CAP SCR
7	4	1-12-081	3/8" X 4" SS HEX HD CAP SCR
8	40	1-13-004	1/4" X 1 1/4" SS HEX HD LAG SCR
9	4	1-20-007	3/8" SS NYLON LOCKNUT
10	16	1-20-020	5/16" SS THIN NYLON LOCKNUT
11	40	1-22-006	1/4" SS FLAT WASHER
12	32	1-22-017	5/16" SS FLAT WASHER
13	4	1-22-024	3/8" SS FLAT WASHER
14	1	49-22	22 GAL PL LINER W/HANDLE, BLK

**KITS PROVIDED FOR S-2**

ITEM	QTY	PART NO	DESCRIPTION
15	1	K-41	41 SER HARDWARE KIT
16	1	K-ANC0860-4	1/2" X 3 3/4" SS ANCHOR KIT (4PC)
17	1	K-HC0664-4	3/8" CAP HARDWARE KIT (4PC)



**ASSEMBLY INSTRUCTIONS**

DATE DRAWN : 12/19/14  
 DRAWN BY : ESS  
 DATE REV. : XX/XX/XX  
 REV. BY : XXX

REV.  
A

DRAWING NUMBER

85-22PL  
W/ CVR-30-BT

SHEET  
2 OF 2

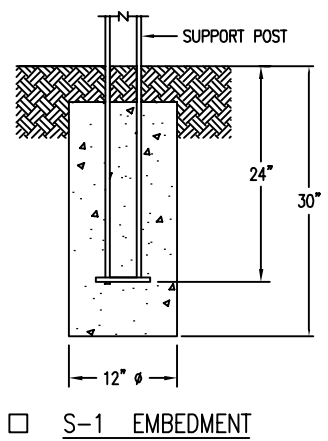
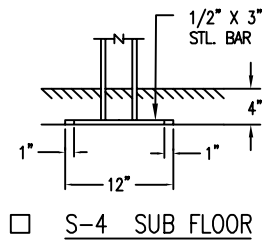
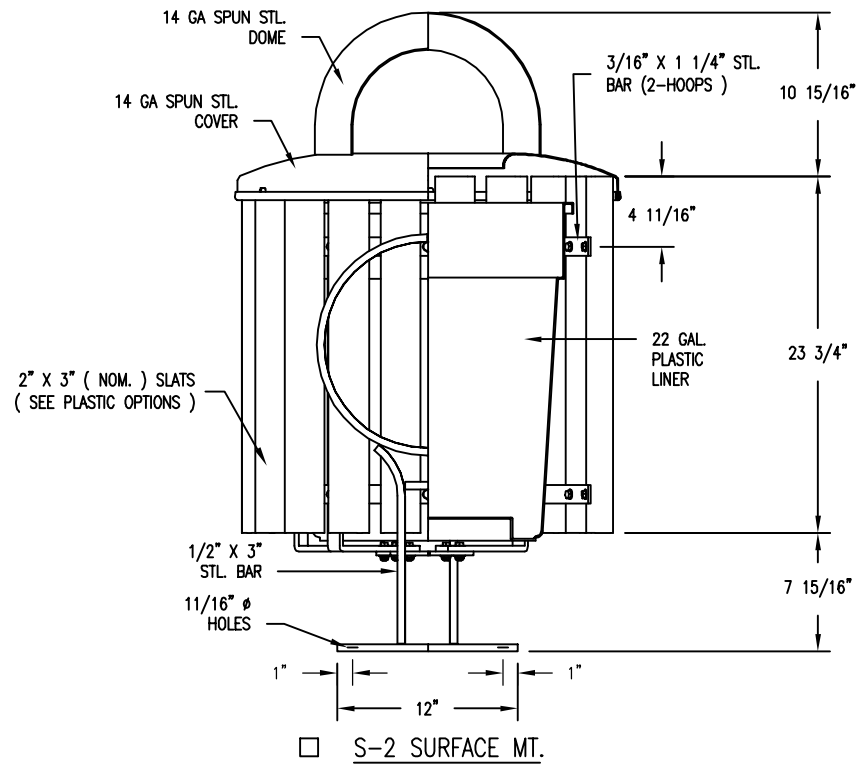
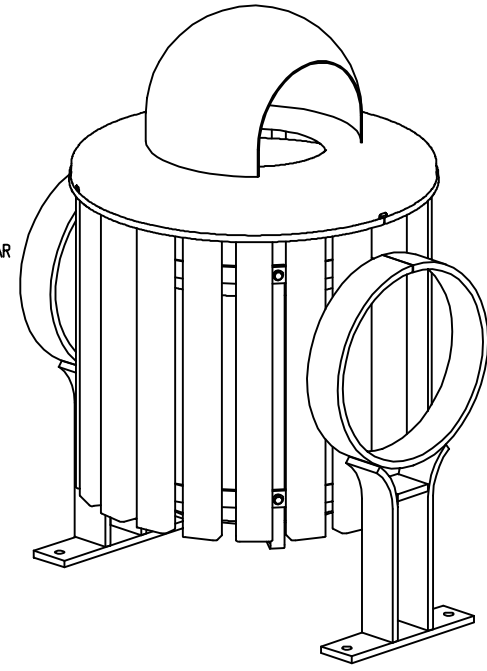
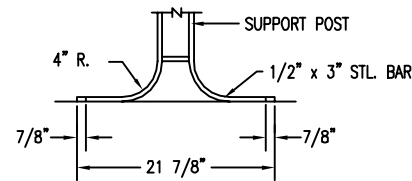
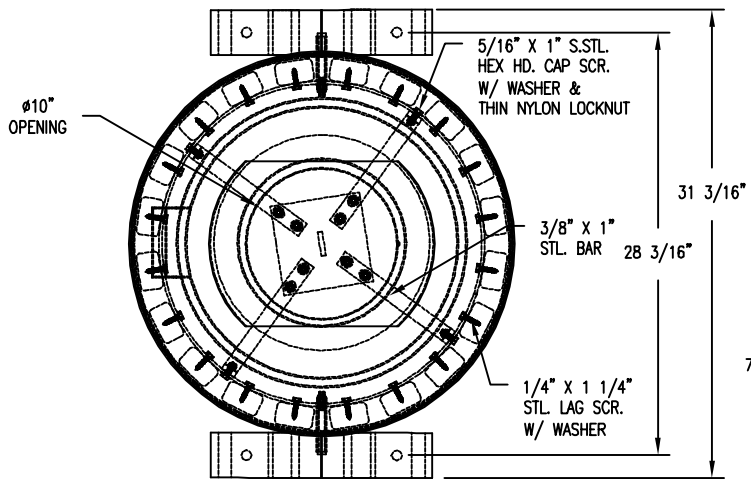

SLAT OPTIONS

- "CEDAR" RECYCLED PLASTIC
- "GREY" RECYCLED PLASTIC
- "REDWOOD" RECYCLED PLASTIC
- "WALNUT" RECYCLED PLASTIC
- OTHER \_\_\_\_\_

NOTES

- 1.) ALL STL. MEMBERS COATED W/ ZINC RICH EPOXY THEN FINISHED W/ POLYESTER POWDER COATING.
- 2.) 1/2" X 3 3/4" EXPANSION ANCHOR BOLTS PROVIDED FOR OPTIONS S-2, S-3, & S-4.



RECEPTACLE

DATE DRAWN : 12/02/04  
 DRAWN BY : JSB  
 DATE REV. : 00/00/00  
 REV. BY : XXX

REV.  
A

DRAWING  
NUMBER

85-22PL  
W/ CVR-30-DM

SHEET  
1 OF 2

**NOTES:**

- 1.) DURING ASSEMBLY PROCEDURE;  
DO NOT COMPLETELY TIGHTEN HARDWARE.
- 2.) THE ACTUAL PARTS WILL NOT BE NUMBERED.  
NUMBERS ONLY APPLY TO DRAWING.
- 3.) UPON COMPLETION OF ASSEMBLY SQUARE  
ALL COMPONENTS THEN TIGHTEN ALL HARDWARE.
- 4.) MOUNT AND ANCHOR AS SPECIFIED.

**TOOLS REQ'D**

- 3/4" WRENCH
- 9/16" WRENCH
- 1/2" WRENCH
- 7/16" WRENCH
- PLIERS ( FOR ATTACHING COVER )
- 1/2" MASONRY DRILL BIT
- DRILL

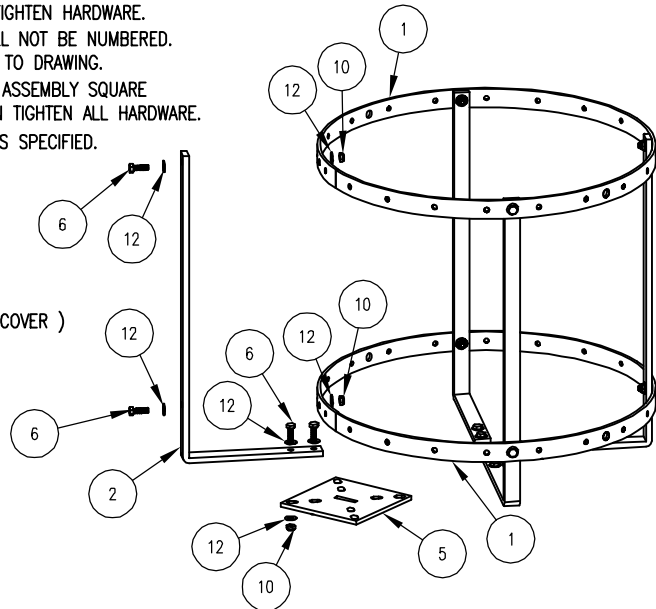

**1** ATTACH HOOPS, CENTER PLATE & "L" SUPPORT STRAPS TOGETHER.

**2** ATTACH SLATS TO STEP 1.

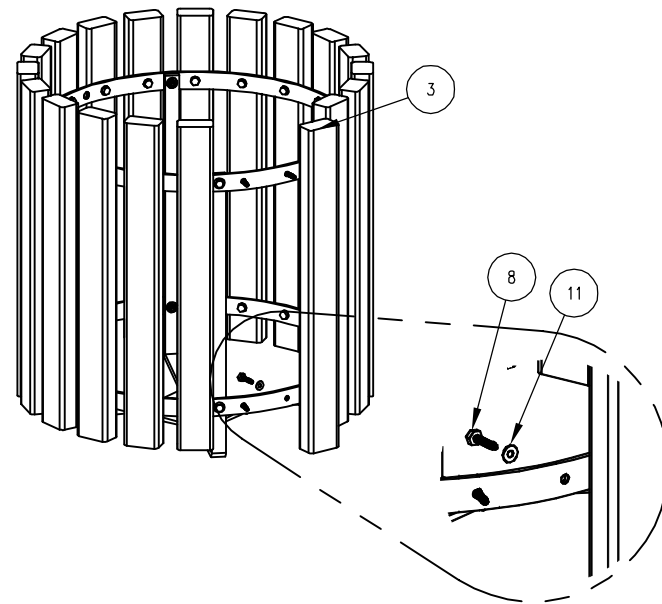

**3** ATTACH SUPPORTS TO STEP 2.

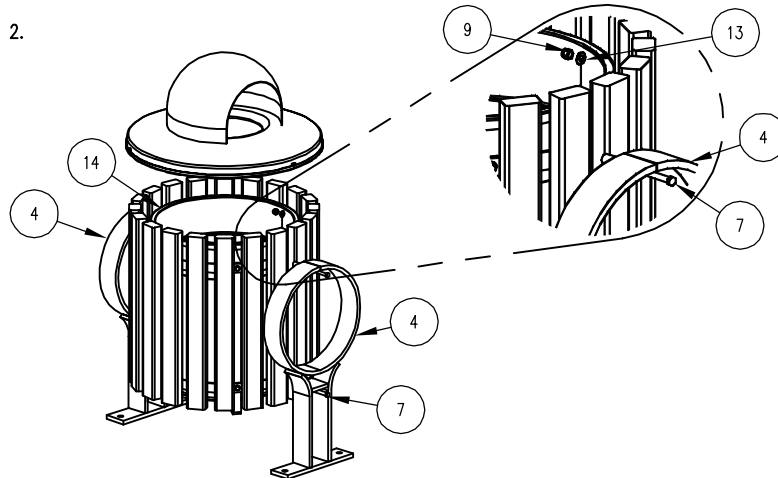

**PARTS LIST FOR S-2**

ITEM	QTY	PART NO	DESCRIPTION
1	2	0-41-20-02	HOOP FOR 20 GAL ( 21 11/16" DIA )
2	4	0-41-20-05	"L" SUPPORT STRAP FOR 20 GAL
3	20	0-41-20PL-01	2" X 3" X 23 3/4" SLAT, PLASTIC
4	2	0-85-00-01/S-2	SUPPORT FOR SURFACE MOUNT
5	1	0-85-00-02	CENTER PLATE ( 85 )
6	16	1-12-061	5/16" X 1" SS HEX HD CAP SCR
7	4	1-12-081	3/8" X 4" SS HEX HD CAP SCR
8	40	1-13-004	1/4" X 1 1/4" SS HEX HD LAG SCR
9	4	1-20-007	3/8" SS NYLON LOCKNUT
10	16	1-20-020	5/16" SS THIN NYLON LOCKNUT
11	40	1-22-006	1/4" SS FLAT WASHER
12	32	1-22-017	5/16" SS FLAT WASHER
13	4	1-22-024	3/8" SS FLAT WASHER
14	1	49-22	22 GAL PL LINER W/HANDLE, BLK

**KITS PROVIDED FOR S-2**

ITEM	QTY	PART NO	DESCRIPTION
15	1	K-41	41 SER HARDWARE KIT
16	1	K-ANC0860-4	1/2" X 3 3/4" SS ANCHOR KIT (4PC)
17	1	K-HC0664-4	3/8" CAP HARDWARE KIT (4PC)



**ASSEMBLY INSTRUCTIONS**

DATE DRAWN : 12/19/14  
 DRAWN BY : ESS  
 DATE REV. : XX/XX/XX  
 REV. BY : XXX

REV.  
A

DRAWING NUMBER

85-22PL  
W/ CVR-30-DM

SHEET  
2 OF 2

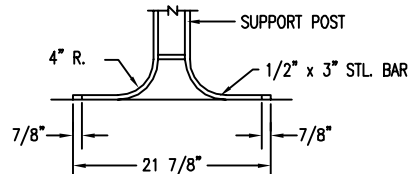
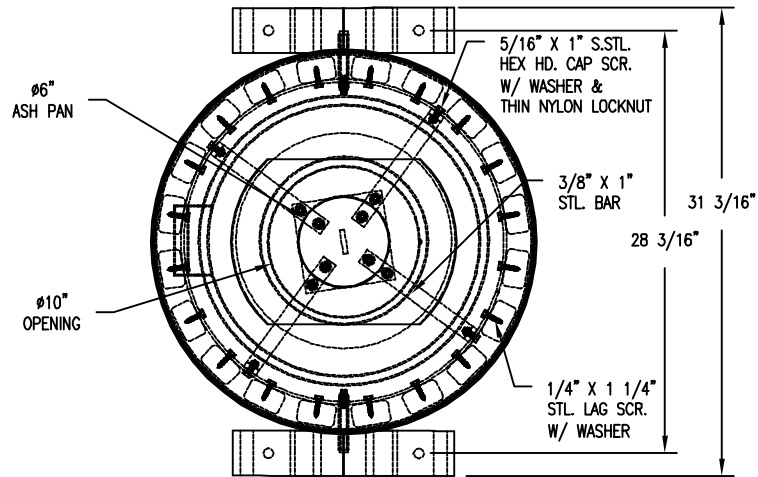

S-3 GULL WING

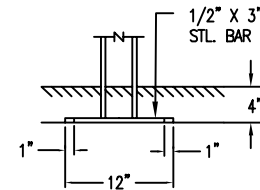
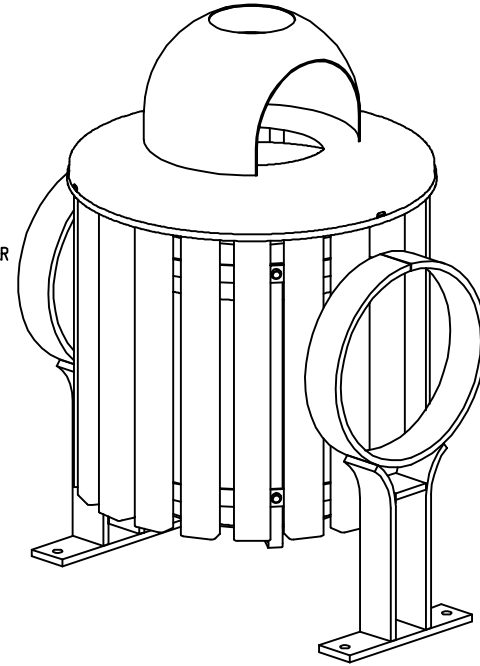

S-4 SUB FLOOR

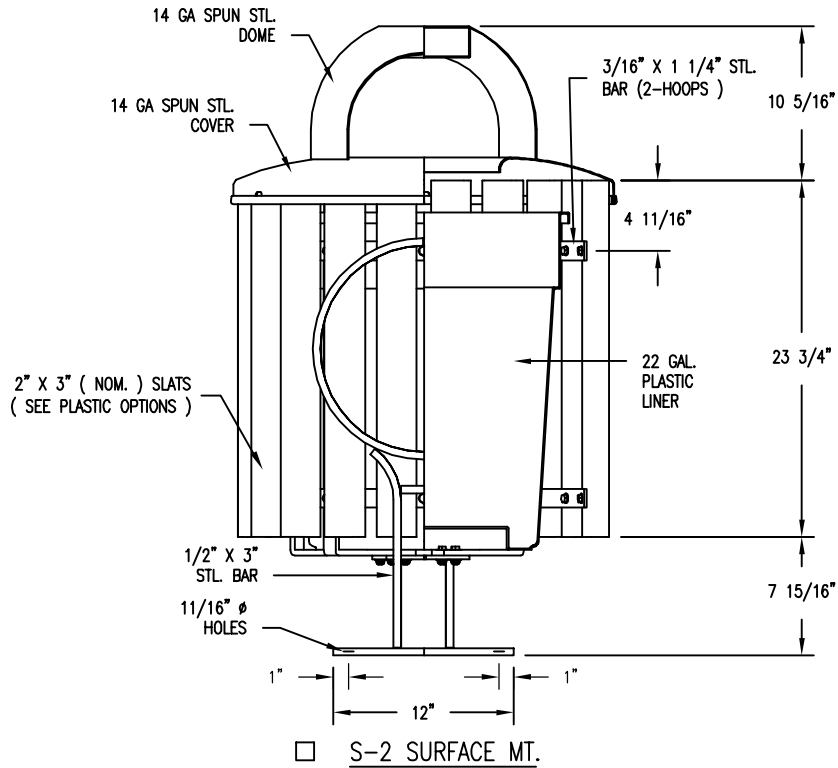

S-2 SURFACE MT.

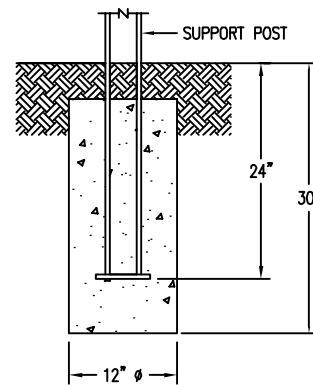

S-1 EMBEDMENT

SLAT OPTIONS

- "CEDAR" RECYCLED PLASTIC
- "GREY" RECYCLED PLASTIC
- "REDWOOD" RECYCLED PLASTIC
- "WALNUT" RECYCLED PLASTIC
- OTHER \_\_\_\_\_

NOTES

- 1.) ALL STL. MEMBERS COATED W/ ZINC RICH EPOXY THEN FINISHED W/ POLYESTER POWDER COATING.
- 2.) 1/2" X 3 3/4" EXPANSION ANCHOR BOLTS PROVIDED FOR OPTIONS S-2, S-3, & S-4.



RECEPTACLE

DATE DRAWN : 11/25/02  
 DRAWN BY : CDC  
 DATE REV. : 00/00/00  
 REV. BY : XXX

REV.  
A

DRAWING  
NUMBER

85-22PL  
W/ CVR-30-DMA

SHEET  
1 OF 2

**NOTES:**

- 1.) DURING ASSEMBLY PROCEDURE;  
DO NOT COMPLETELY TIGHTEN HARDWARE.
- 2.) THE ACTUAL PARTS WILL NOT BE NUMBERED.  
NUMBERS ONLY APPLY TO DRAWING.
- 3.) UPON COMPLETION OF ASSEMBLY SQUARE  
ALL COMPONENTS THEN TIGHTEN ALL HARDWARE.
- 4.) MOUNT AND ANCHOR AS SPECIFIED.

**TOOLS REQ'D**

- 3/4" WRENCH
- 9/16" WRENCH
- 1/2" WRENCH
- 7/16" WRENCH
- PLIERS ( FOR ATTACHING COVER )
- 1/2" MASONRY DRILL BIT
- DRILL

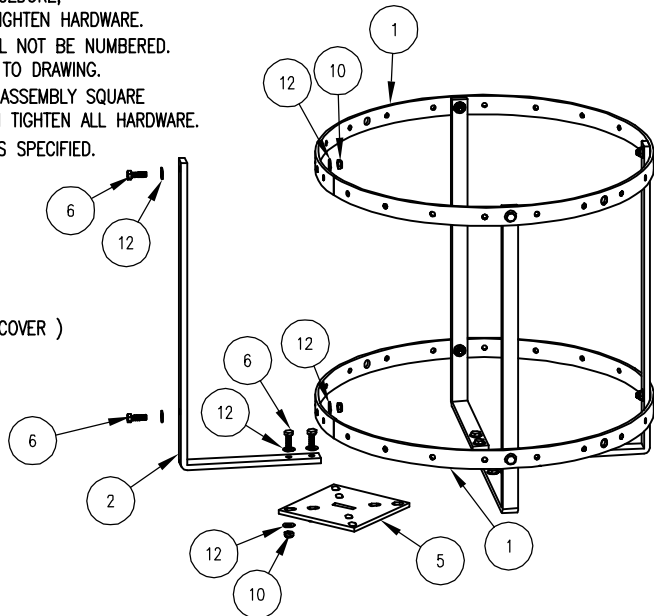

**1** ATTACH HOOPS, CENTER PLATE & "L" SUPPORT STRAPS TOGETHER.

**2** ATTACH SLATS TO STEP 1.

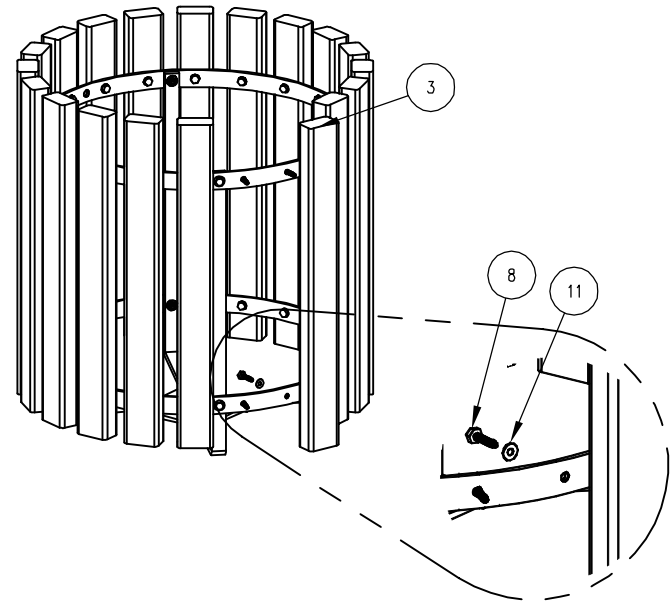

**3** ATTACH SUPPORTS TO STEP 2.

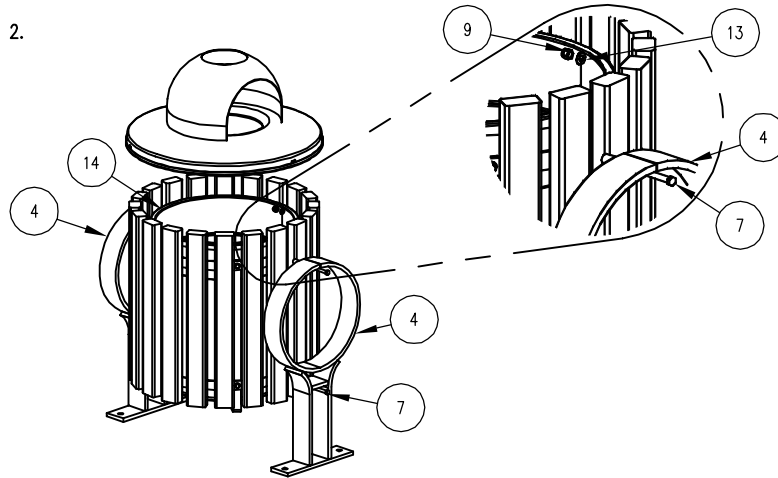

**PARTS LIST FOR S-2**

ITEM	QTY	PART NO	DESCRIPTION
1	2	0-41-20-02	HOOP FOR 20 GAL ( 21 11/16" DIA )
2	4	0-41-20-05	"L" SUPPORT STRAP FOR 20 GAL
3	20	0-41-20PL-01	2" X 3" X 23 3/4" SLAT, PLASTIC
4	2	0-85-00-01/S-2	SUPPORT FOR SURFACE MOUNT
5	1	0-85-00-02	CENTER PLATE ( 85 )
6	16	1-12-061	5/16" X 1" SS HEX HD CAP SCR
7	4	1-12-081	3/8" X 4" SS HEX HD CAP SCR
8	40	1-13-004	1/4" X 1 1/4" SS HEX HD LAG SCR
9	4	1-20-007	3/8" SS NYLON LOCKNUT
11	40	1-22-006	1/4" SS FLAT WASHER
12	32	1-22-017	5/16" SS FLAT WASHER
13	4	1-22-024	3/8" SS FLAT WASHER
14	1	49-22	22 GAL PL LINER W/HANDLE, BLK
10	16	1-20-020	5/16" SS THIN NYLON LOCKNUT

**KITS PROVIDED FOR S-2**

ITEM	QTY	PART NO	DESCRIPTION
15	1	K-41	41 SER HARDWARE KIT
16	1	K-ANC0860-4	1/2" X 3 3/4" SS ANCHOR KIT (4PC)
17	1	K-HC0664-4	3/8" CAP HARDWARE KIT (4PC)



**ASSEMBLY INSTRUCTIONS**

DATE DRAWN : 12/19/14  
 DRAWN BY : ESS  
 DATE REV. : XX/XX/XX  
 REV. BY : XXX

REV.  
A

DRAWING NUMBER

85-22PL  
W/ CVR-30-DMA

SHEET  
2 OF 2

**MINUTES OF MEETING  
OAK CREEK  
COMMUNITY DEVELOPMENT DISTRICT**

The regular meeting of the Board of Supervisors of the Oak Creek Community Development District was held on Monday, April 13, 2026, and called to order at 6:00 p.m. located at the Watergrass Clubhouse, 32711 Windelstraw Dr., Wesley Chapel, FL 33545.

Present and constituting a quorum were:

Sam Watson	Chairperson
Michael Rudman	Vice Chairperson
Ryan Gilbertsen	Assistant Secretary
Lisa Vaile	Assistant Secretary
David Gerald	Assistant Secretary

Also present, either in person or via communication media technology, were:

Christina Newsome	District Manager, Inframark
Robert Dvorak	District Engineer, JMT
Carri Allen Webster	District Counsel, Straley Robin Vericker
Carlos Santana	Field Manager, Inframark
Mark Vega	Senior District Manager, Inframark
Shiller	Representative, SGD Communications
Residents	

*This is not a certified or verbatim transcript but rather represents the context and summary of the meeting. The full meeting is available in audio format upon request. Contact the District Office for any related costs for an audio copy.*

**FIRST ORDER OF BUSINESS**

**Call to Order / Roll Call**

Ms. Newsome called the meeting to order and a quorum was established.

**SECOND ORDER OF BUSINESS**

**Pledge of Allegiance**

The Pledge of Allegiance was recited.

**THIRD ORDER OF BUSINESS**

**Approval of Agenda**

The Board approved the agenda.

**FOURTH ORDER OF BUSINESS**

**Audience Comments**

Multiple residents provided comments regarding concerns with Pond 24 and requested clarification on what actions the Board intends to take to remedy the situation.

**FIFTH ORDER OF BUSINESS**

**Staff Reports**

**A. District Accountant**

**i. Review of Financials**

**ii. Acceptance of Check Register**

Mr. Haller presented the financials and answered questions from the Board.

OAK CREEK CDD  
April 13, 2026

46 **B. District Counsel**

47 Ms. Webster discussed litigation matters related to Sitemasters and provided the Board with  
48 options for consideration. Ms. Newsome reviewed the engagement letter from Pasket, Divers,  
49 Thompson with the Board. Discussion also ensued regarding trespassing and related limitations  
50 within Pasco County.

51  
52 On MOTION by Mr. Gilbertson, seconded by Mr. Gerald, with all in  
53 favor, the Board approved engagement of Paskert, Divers, Thompson,  
54 P.A., in an amount not to exceed \$2,400. (5-0)

55  
56 **C. District Engineer**

57 Mr. Dvorak provided an update on the Pond 24 project, including background on the  
58 previous vendor. Mr. Dvorak discussed the scope of work and reviewed a current proposal from  
59 Finn Outdoor in the amount of \$32,000.

60 The Board inquired about any change orders that may have been submitted for the previous  
61 work.

62 **D. District Manager**

63 Ms. Newsome provided her report and answered questions from the Board. Ms. Newsome  
64 noted that the next regular Board meeting will be held on Monday, May 11, 2026, at 6:00 p.m.

65 **E. Field Manager Report**

66 Mr. Santana provided his report and answered questions from the Board.

67 **i. Inframark Little Free Library Replacement Proposal**

68 The Board discussed the current proposal and other options for replacement of the Little Free  
69 Library. Discussion included returning the original bookshelf to Natasha.

70  
71 On MOTION by Mr. Watson, seconded by Mr. Gerald, with all in favor,  
72 the Board approved Inframark Little Free Library Replacement Proposal  
73 subject to Chair approval outside of a meeting. (5-0)

74  
75 **ii. Consideration of Inframark Pool Gate Repair and Paver Replacement Proposal**

76 The Board discussed the Time On Target Pro Security Proposal. The item was tabled for  
77 additional bids.

78 On MOTION by Mr. Watson, seconded by Mr. Gerald, with all in favor,  
79 the Board approved Inframark Pool Gate Repair and Paver Replacement  
80 Proposal in the amount of \$525. (5-0)

81

**iii. Review of Inframark Seasonal Pool Monitor Services Proposal**

Mr. Vega presented the pool monitoring schedule and reviewed the breakdown with the Board.

**iv. Consideration of Inframark Sidewalk Repair Proposal**

On MOTION by Mr. Watson, seconded by Mr. Gilbertson, with all in favor, the Board approved Inframark Sidewalk Repair Proposal in an amount not to exceed \$500. (5-0)

**v. Consideration of Magic Bubbles Pressure Cleaning and Site Improvements Proposal**

On MOTION by Mr. Gerald, seconded by Mr. Watson, with all in favor, the Board approved the Prince Pressure Washing proposal in the amount of \$4,600. (5-0)

**F. Aquatics Report**

The Board reviewed the Aquatics Report.

**G. Landscape Report**

**i. Consideration of Juniper Landscaping Tree Removal and Stump Grinding Proposal**

The Board discussed the proposal in relation to the hold harmless agreement, noting that the removal would be separate from that issue.

**ii. Consideration of Juniper Landscaping Irrigation Repairs Controllers #1 and #6 Proposal**

On MOTION by Mr. Rudman, seconded by Mr. Watson, with all in favor, the Board approved Juniper Landscaping Irrigation Repairs Controllers #1 and #6 Proposal in the amount of \$1,184.94. (5-0)

**iii. Consideration of Juniper Landscaping Irrigation Controller Replacement Proposal**

On MOTION by Mr. Gilbertson, seconded by Mr. Watson, with all in favor, the Board approved Juniper Landscaping Irrigation Controller Replacement Proposal. (5-0)

**SIXTH ORDER OF BUSINESS**

**Business Item**

**A. Consideration of Tree Removal and Hold Harmless Agreement**

Ms. Webster presented the agreement and answered questions from the Board.

On MOTION by Mr. Gerald, seconded by Mr. Watson, with all in favor, the Board approved the Hold Harmless Agreement. (5-0)

OAK CREEK CDD  
April 13, 2026

125 **SEVENTH ORER OF BUSINESS** **Business Administration**  
126 **A. Consideration of Minutes from the Meeting Held March 9, 2026**

127  
128  
129  
130  
131

On MOTION by Mr. Gilbertson, seconded by Mr. Watson, with all in favor, the minutes of the meeting held March 9, 2026, were approved. (5-0)

132 **SEVENTH ORDER OF BUSINESS** **Supervisor Requests and Comments**

133  
134  
135  
136  
137  
138  
139

Mr. Gerald provided expectations for vendors performing work within the District.  
Ms. Vaile requested that reminders be sent to the Board regarding the June 6 and August 8 workshops and discussed potential landscape enhancement options.  
Mr. Gilbertson mentioned the removal of declining bushes along Sparkling Way.  
Mr. Rudman had no requests.  
Mr. Watson thanked the Board and staff for their efforts in keeping the District operating smoothly.

140 **EIGHTH ORDER OF BUSINESS** **Adjournment**

141 With there being no other business,

142  
143  
144  
145  
146  
147  
148

On MOTION by Mr. Gilbertson, seconded by Mr. Watson, with all in favor, the meeting was adjourned at 8:28 p.m. (5-0)

\_\_\_\_\_  
Sam Watson, Chairman